

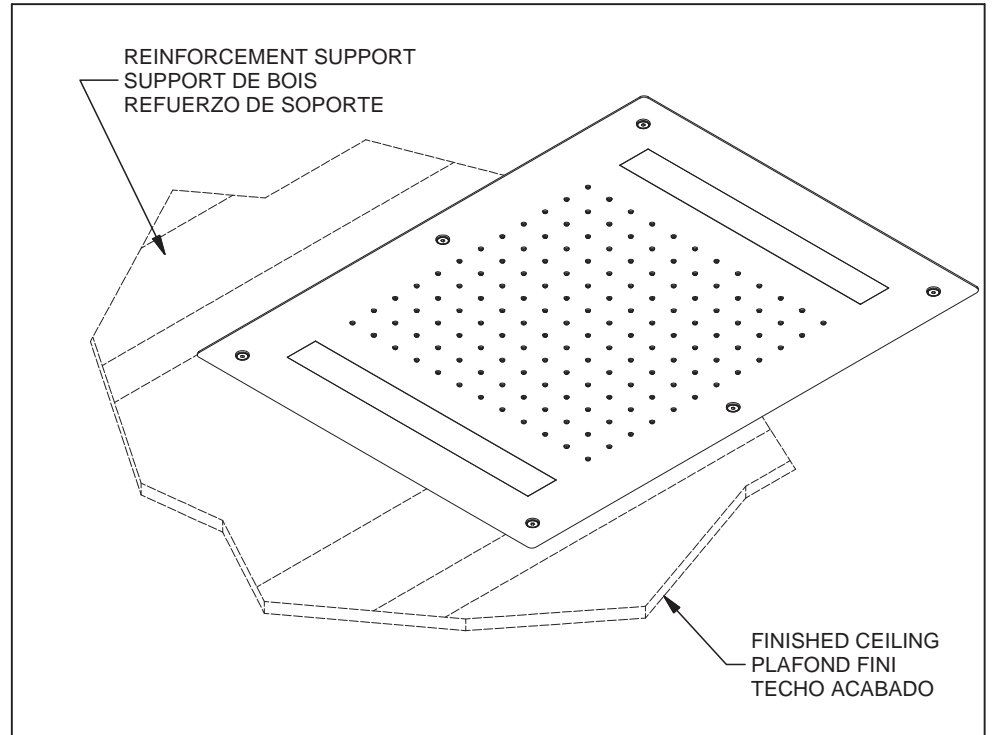

Installation guide / Guide d'installation / Guía de instalación

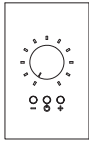
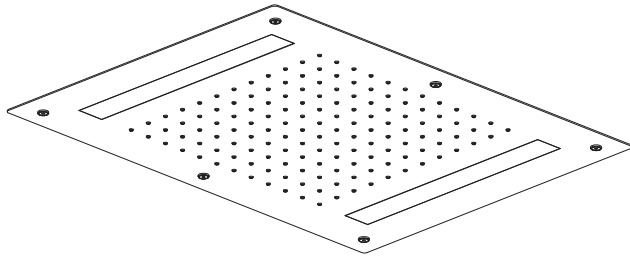

**Before beginning the installation:**

Read all instructions.

Purge the water supply system before connecting it to the faucet.

**Avant de commencer l'installation:**

Lire toutes les instructions.

Purger votre système d'alimentation d'eau avant d'effectuer le branchement au robinet.

**Antes de iniciar la instalación:**

Lea todas las instrucciones.

Es necesario purgar previamente su sistema de alimentación de agua para efectuar la conexión del grifo.

**Tools and equipment required / Outils et autre matériel requis / Se requieren herramientas y otros equipos para la instalación :**



riobel.ca

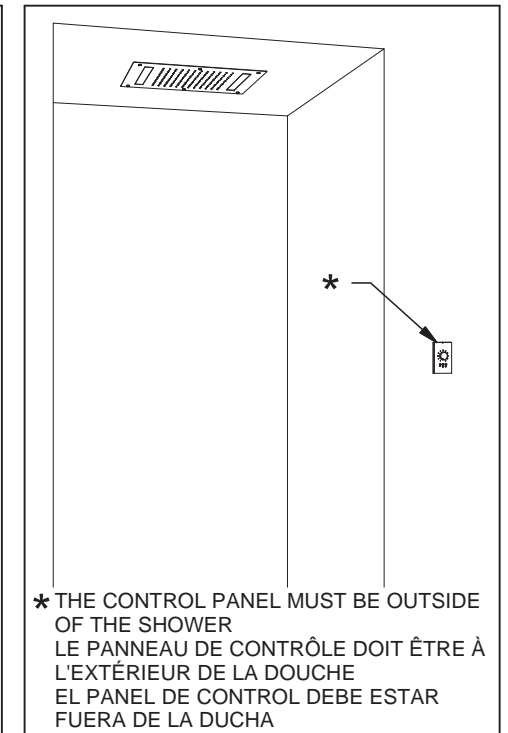
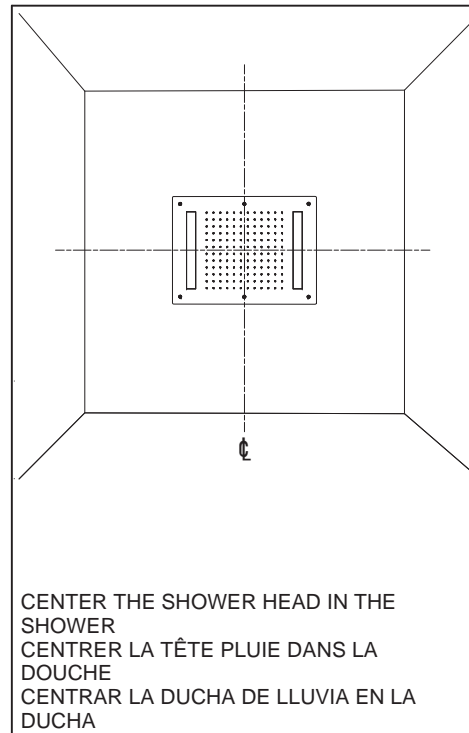

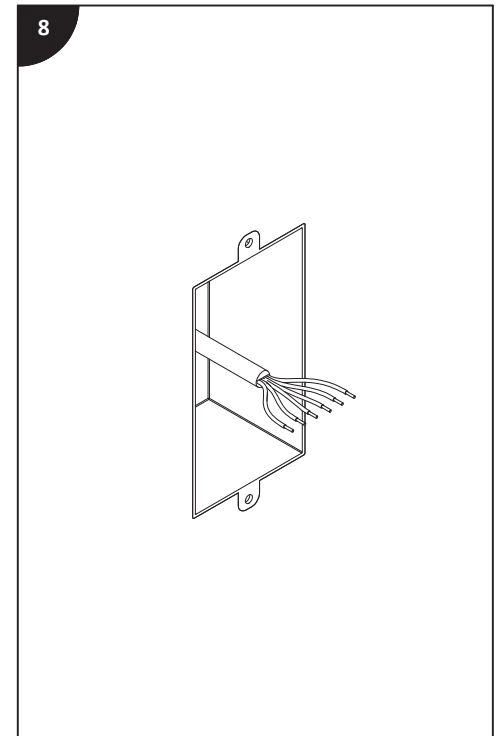
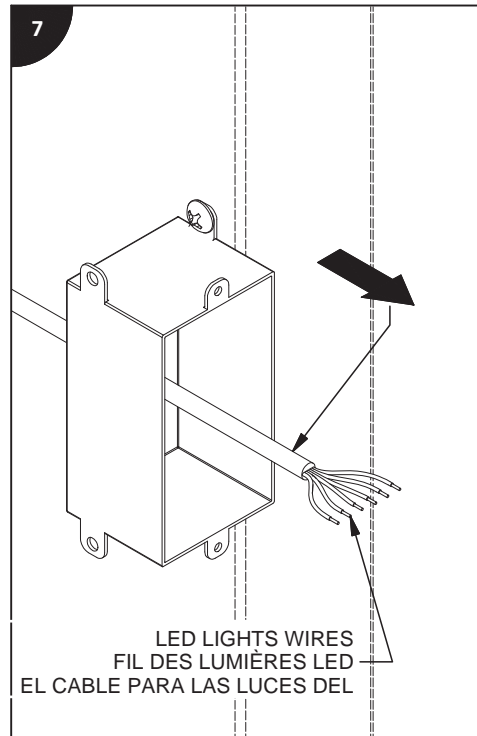
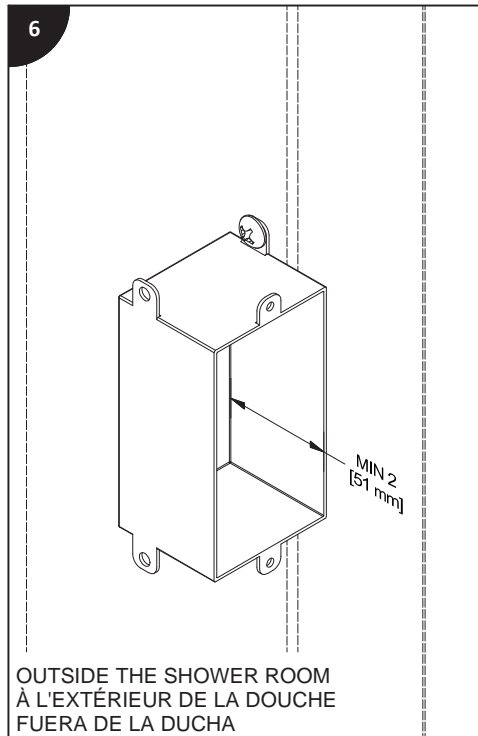
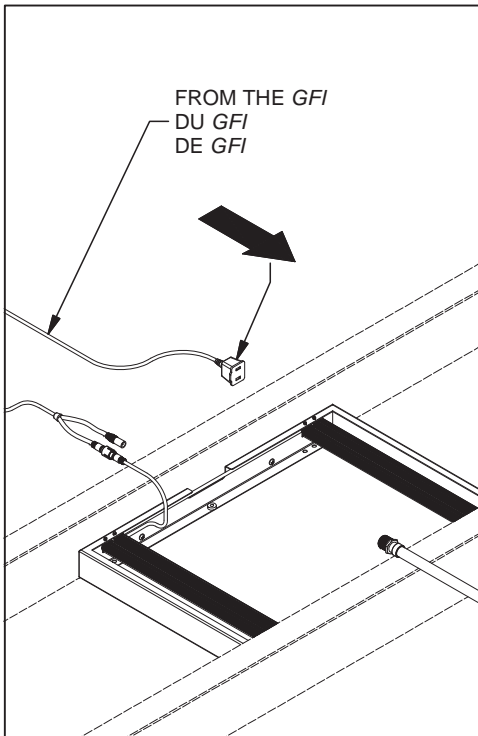
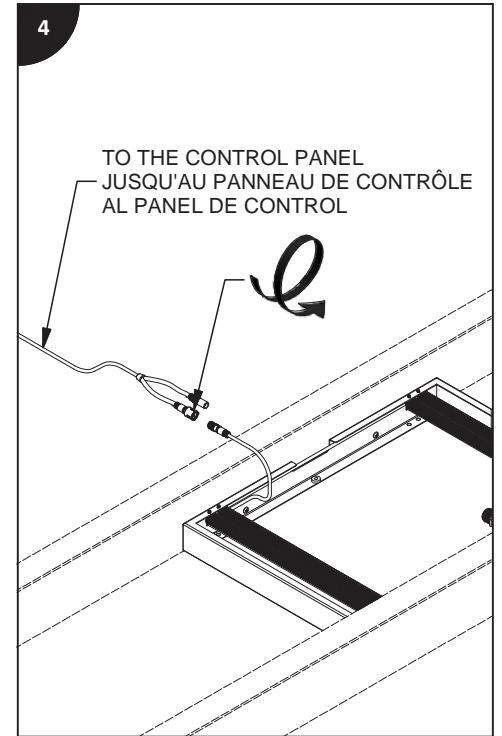
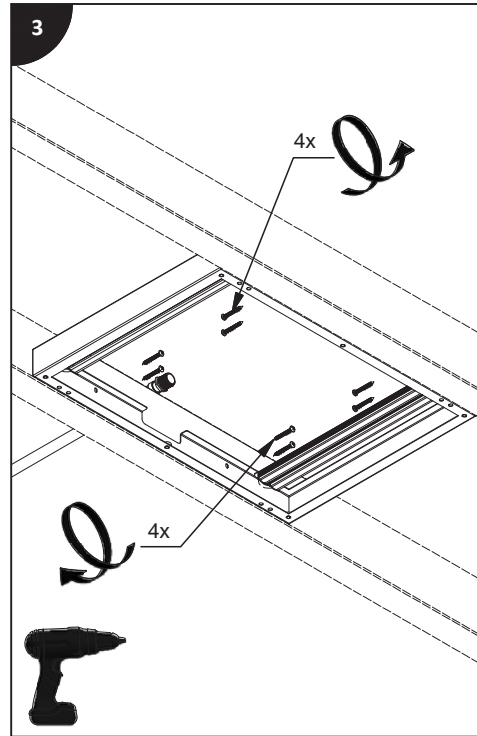
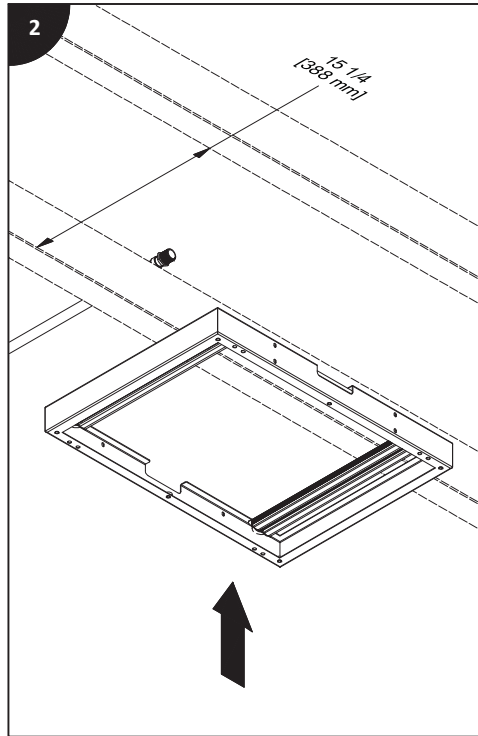
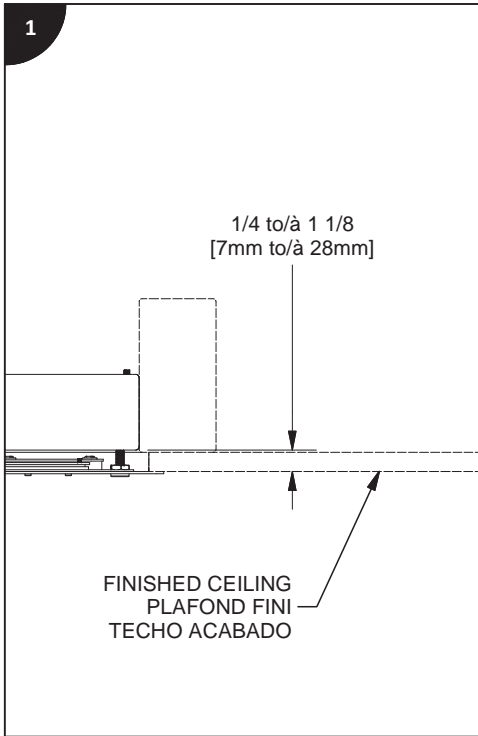

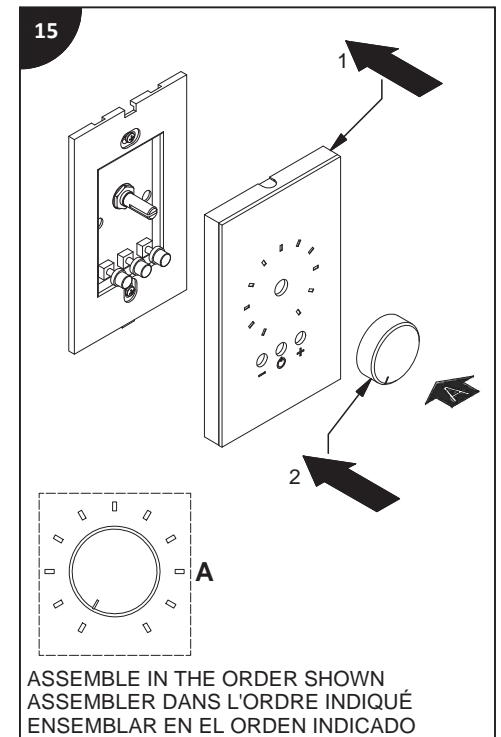
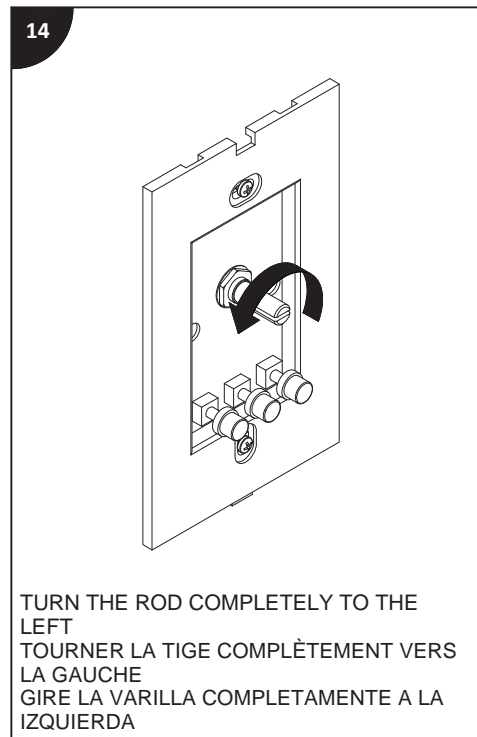
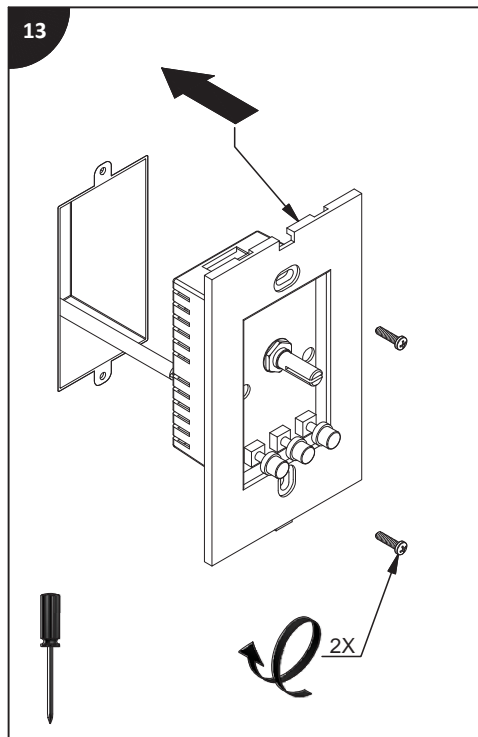
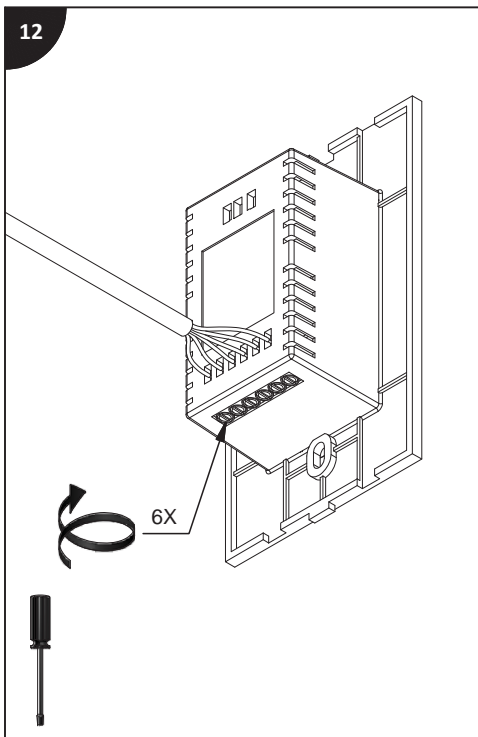
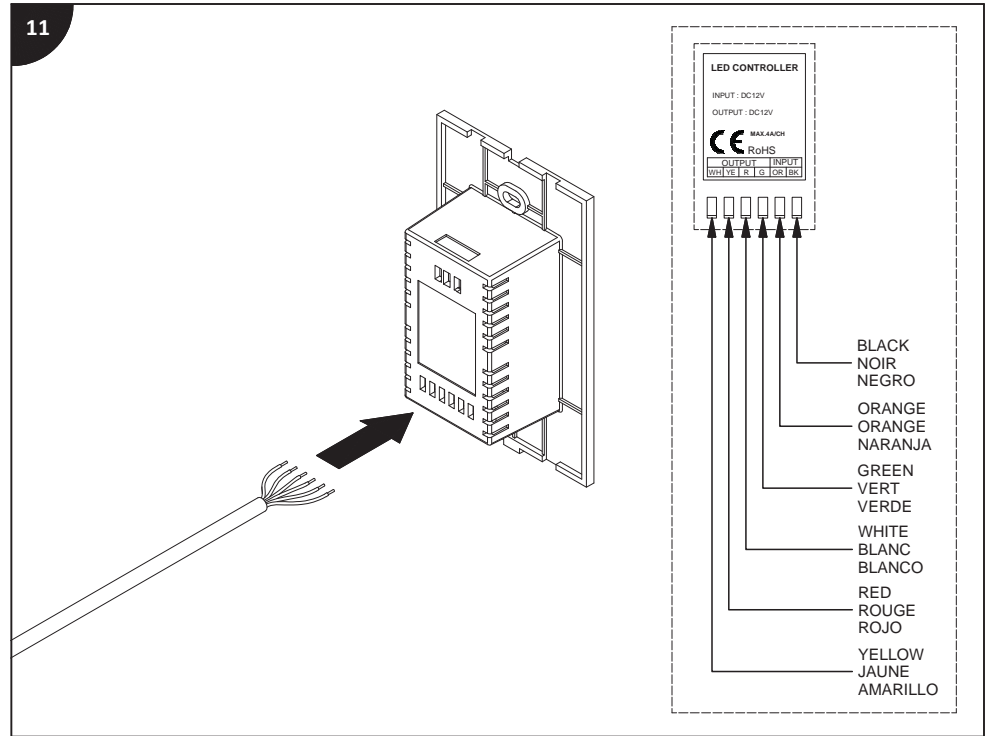
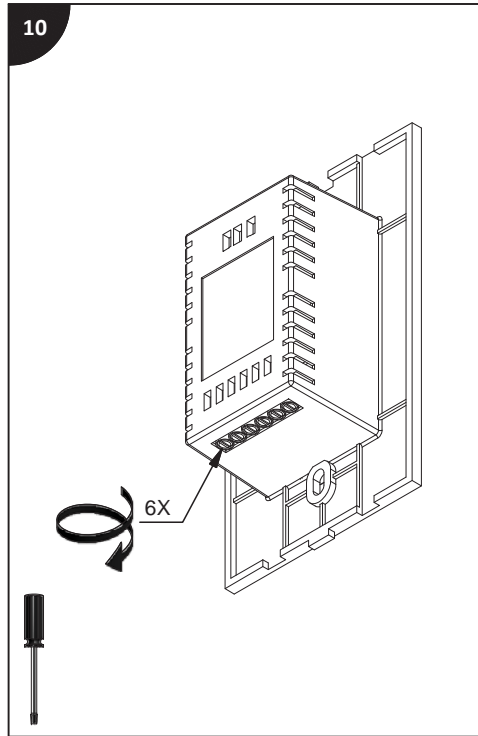
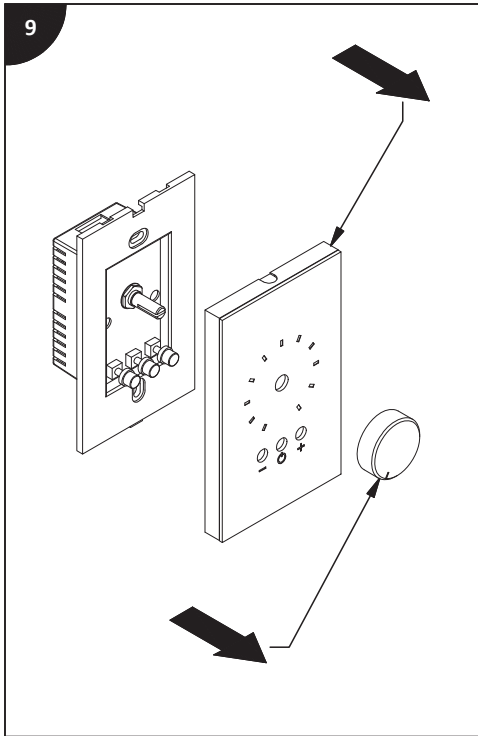

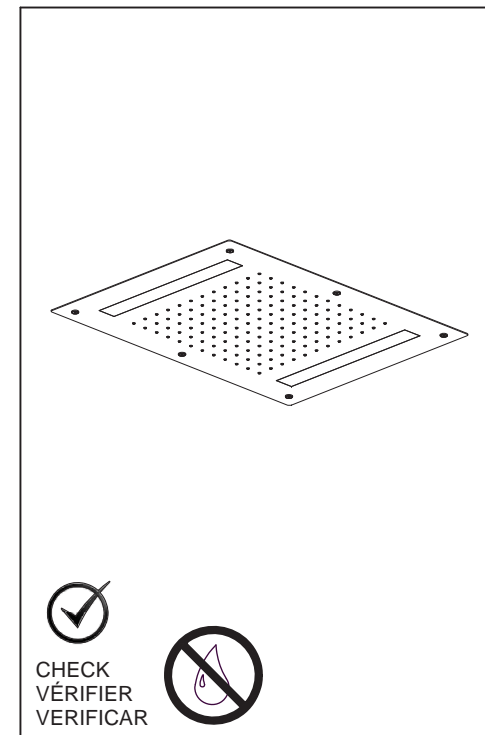
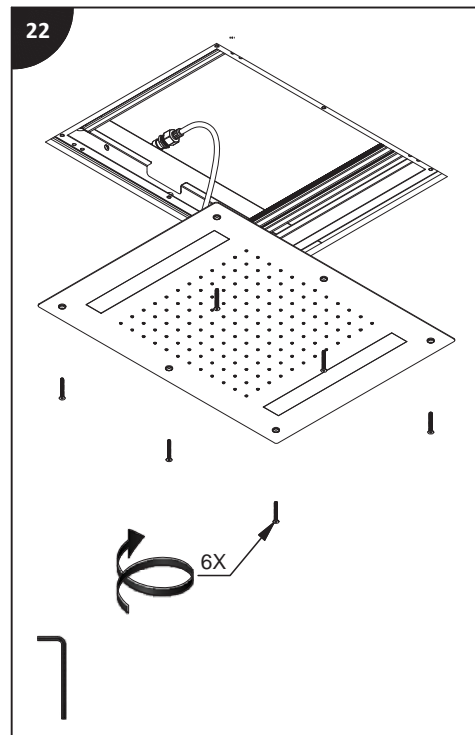
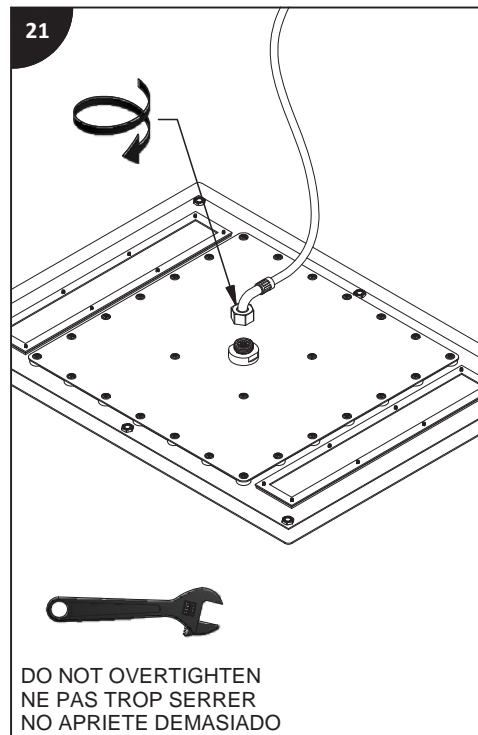
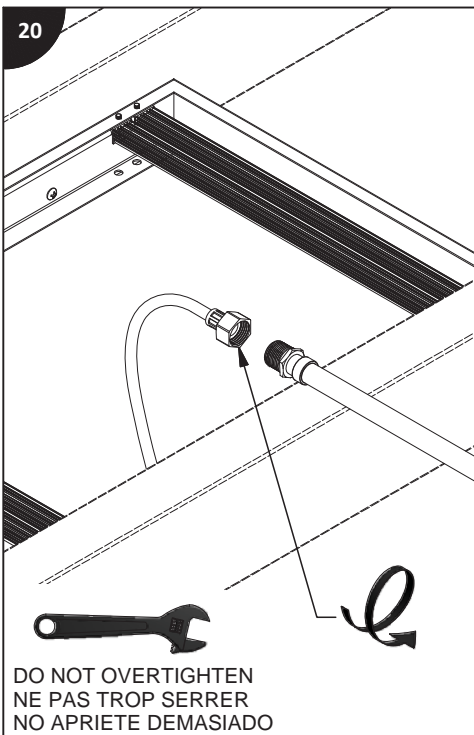
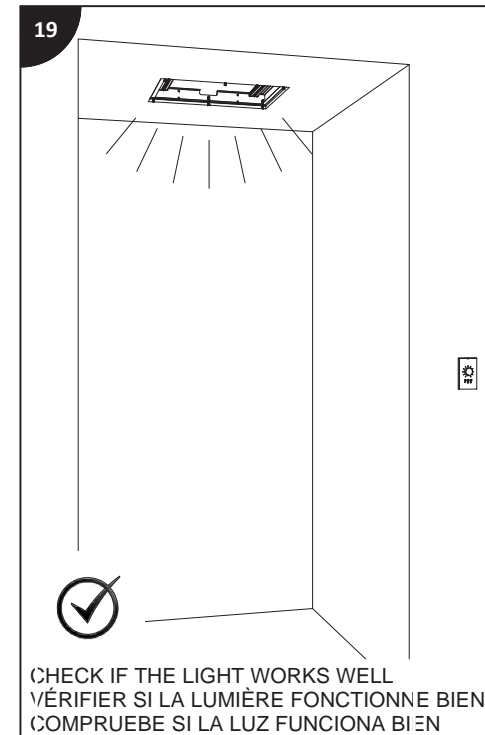
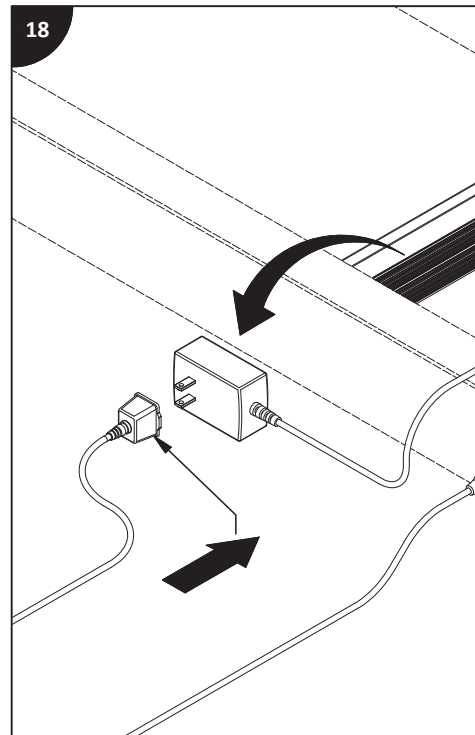
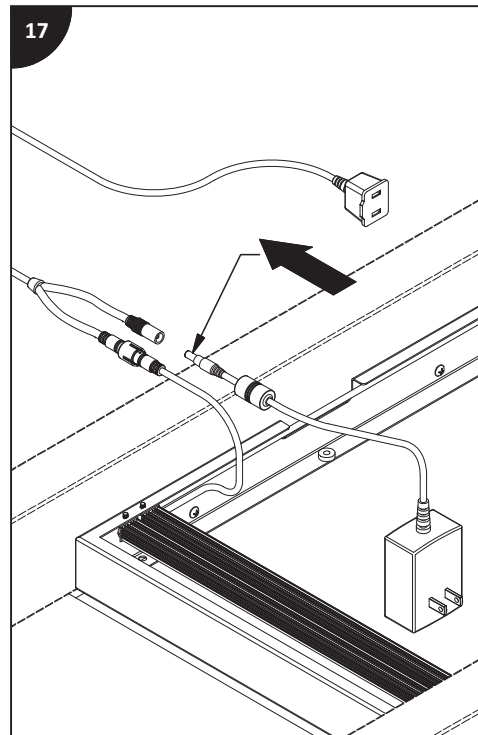
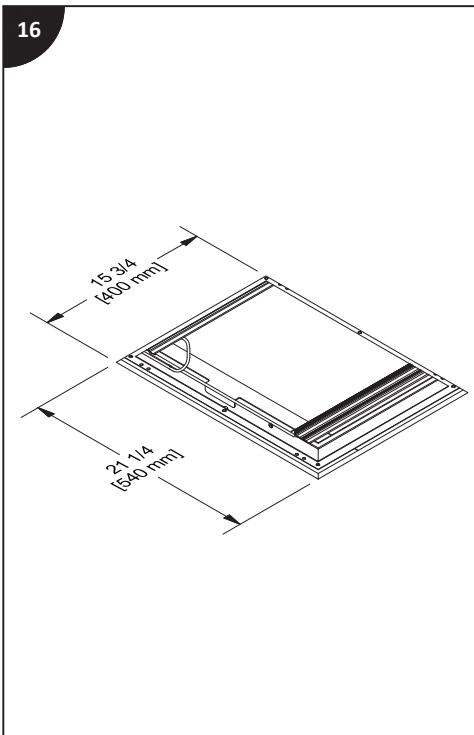

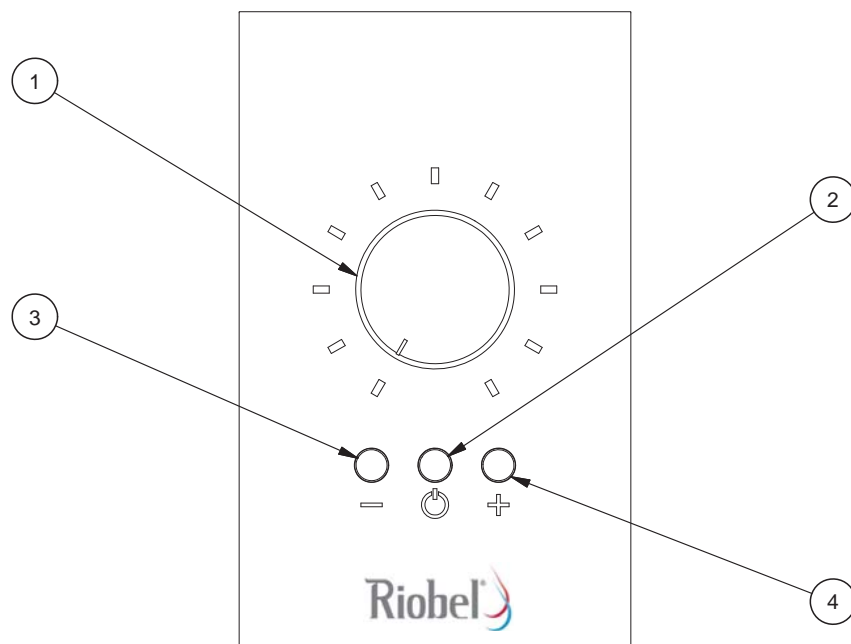

Using the control panel / Utilisation du panneau de contrôle / Uso del panel de control

Item	English	Français	Español
1	<p>Colors chooser wheel :</p> <ul style="list-style-type: none"> <li>- Turn this wheel to adjust the color.</li> </ul>	<p>Sélecteur de couleurs :</p> <ul style="list-style-type: none"> <li>- Tourner cette roulette pour ajuster la couleur.</li> </ul>	<p>Selector de color :</p> <ul style="list-style-type: none"> <li>- Gire la rueda para ajustar el color.</li> </ul>
2	<p>Power and Mode button :</p> <ul style="list-style-type: none"> <li>- Hold this button to turn on/off the light.</li> <li>- Use a quick press to change the pattern.</li> </ul>	<p>Boutton d'alimentation et Modes :</p> <ul style="list-style-type: none"> <li>- Maintenir ce bouton pour allumer et éteindre les lumières.</li> <li>- Appuyer sur le bouton rapidement pour changer le mode d'éclairage.</li> </ul>	<p>Botón de encendido y los modos :</p> <ul style="list-style-type: none"> <li>- Mantenga pulsado el botón para encender y apagar las luces.</li> <li>- Pulse brevemente el botón para cambiar el modo de iluminación.</li> </ul>
3	<p>Brightness and Speed Reducing :</p> <ul style="list-style-type: none"> <li>- Hold the button to decrease the intensity of the light.</li> <li>- Hold the button to decrease the speed of the light modes.</li> </ul>	<p>Réduction de la luminosité et de la Rapidité :</p> <ul style="list-style-type: none"> <li>- Maintenir le bouton enfoncé pour réduire la luminosité.</li> <li>- Maintenir le bouton enfoncé pour réduire la vitesse des modes d'éclairage.</li> </ul>	<p>Reducción del brillo y velocidad :</p> <ul style="list-style-type: none"> <li>- Mantenga pulsado el botón para reducir el brillo.</li> <li>- Mantenga pulsado el botón para reducir la velocidad de los niveles de iluminación</li> </ul>
4	<p>Brightness and Speed Increasing :</p> <ul style="list-style-type: none"> <li>- Hold this button to increase the intensity of the light.</li> <li>- Hold this button to increase the speed of the light modes.</li> </ul>	<p>Augmentation de la luminosité et de la Rapidité :</p> <ul style="list-style-type: none"> <li>- Maintenir le bouton enfoncé pour augmenter la luminosité.</li> <li>- Maintenir le bouton enfoncé pour augmenter la vitesse des modes d'éclairage.</li> </ul>	<p>Aumento del brillo y velocidad :</p> <ul style="list-style-type: none"> <li>- Mantenga pulsado el botón para aumentar el brillo.</li> <li>- Mantenga pulsado el botón para aumentar la velocidad de los niveles de iluminación.</li> </ul>